

VS SERIES 650-850 MM

The DENSO VS-Series six-axis articulated robots offer longer reaches than the VP Series and can handle higher payloads. They are also available in configurations that allow operation in specific environments. Outstanding features include:

- Fast cycle times from 0.59 to 0.49 sec.
- Excellent repeatability from $\pm 0.03\text{mm}$ to $\pm 0.02\text{mm}$
- Payloads up to 7 kg
- Reaches from 650 to 850 mm
- High maximum allowable moment of inertia
- Compact design saves floor space, facilitates integration
- Floor- or ceiling-mount, with no special hardware required
- Operation in dusty and wet environments (optional IP65 configuration)
- Operation in cleanrooms (optional cleanroom class-10 and class-100 configurations)
- ANSI and CE compliance allows global deployment
- UL models available for the US and Canada



VS-6556G



VS-6577G



CEILING-MOUNT OPTION



	VS-6556G	VS-6577G
Number of axes	6	
Overall arm length (mm)	565	770
Second-arm width (mm)	110	
Reach (to center of 5th axis, mm)	653	854
Minimum motion area (mm)	234	242
Maximum payload (kg)	6 (7 with flange pointing down)	
Weight, approx. (kg)	35	36
Footprint (mm × mm)	200 × 200	
Cycle time (sec.)	0.49 (with 1-kg weight)	0.59 (with 1-kg weight)
Maximum composite speed (mm/sec.)	8,200	7,600
Maximum joint speed (°/sec.)	J1: 375 J2: 300 J3: 375 J4: 410 J5: 410 J6: 660	
Repeatability ^{1,2} (mm)	± 0.02	
Maximum allowable moment of inertia (kgm ²)	J4, J5: 0.413 J6: 0.063	
Range of motion (°)	J1 ± 170 J2 +135, -100 J3 +166, -119 J4 ± 190 J5 ± 120 J6 ± 360	
Position detection	Absolute encoder	
Drive motors and brakes	AC servomotors for all axes; brakes on 2nd, 3rd and 4th axis (5th and 6th axis optional)	
Air piping (in-arm integrated)	10 lines (max. 1 A per line)	
Wiring (in-arm integrated)	7 systems ($\phi 4 \times 6$, $\phi 6 \times 1$), three 2-position double solenoid valves	
Protection class	Standard: IP40 Options: IP54/65 (body/wrist), IP65 (dust- and mistproof), cleanroom class 10 ($0.1 \mu\text{m}$) ³ , cleanroom class 100 ($0.3 \mu\text{m}$) ³	
Ceiling-mount ³	✓	
UL specifications ⁴	✓	

1. At constant ambient temperature. 2. In all directions. 3. All except cleanroom models, which can be floor-mounted only. 4. Only for dust- and mistproof model with brakes.



Scan this QR Code®
for more information

VS SERIES 650-850 MM

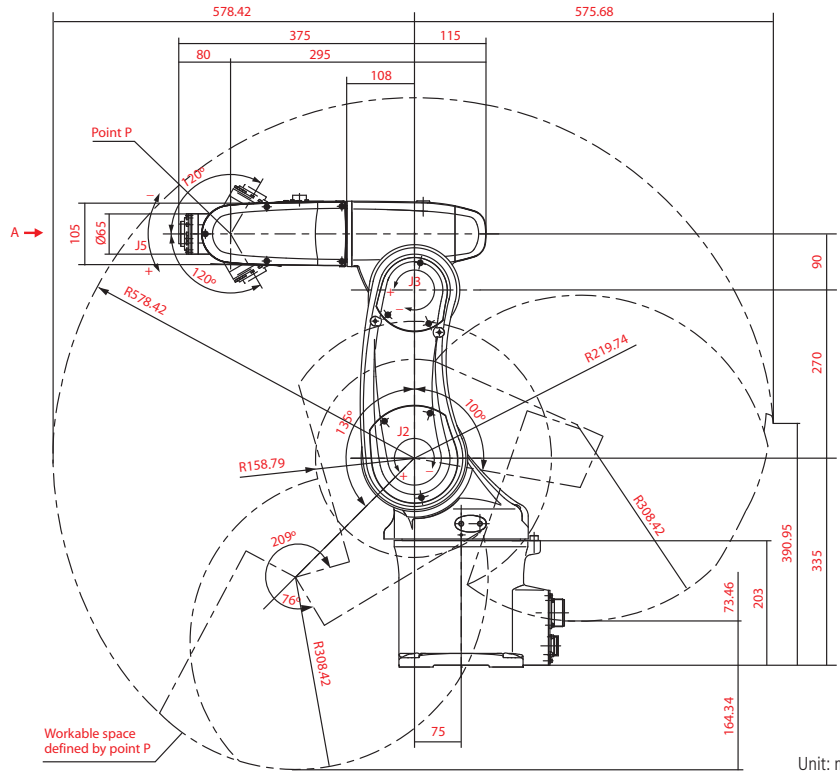

Unit: mm

Detail of end-effector mounting face (view A)

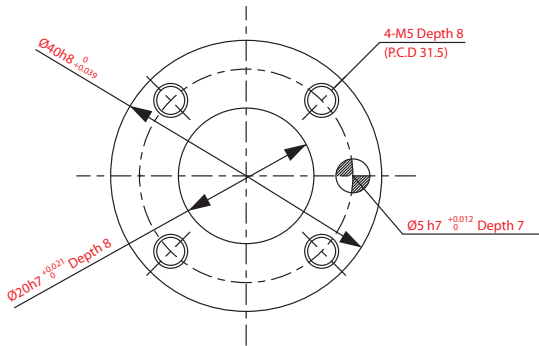

Detailed drawing of base mounting face (top view)

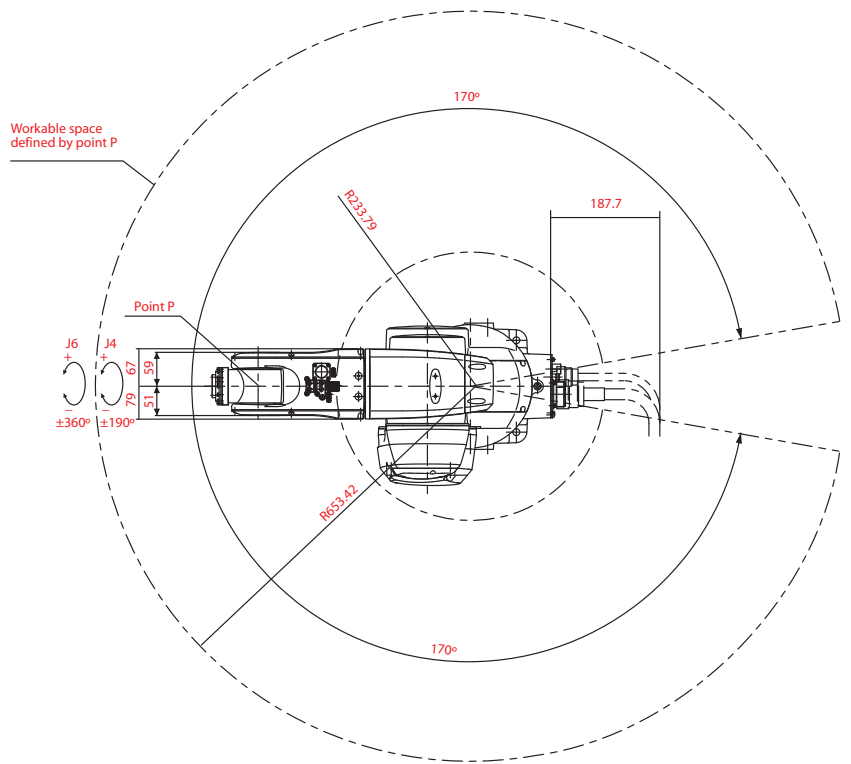
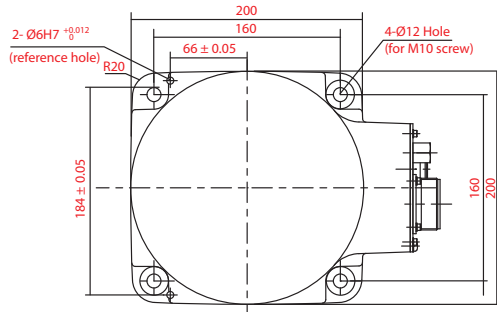

DENSO ROBOTICS

3900 Via Oro Avenue, Long Beach, California 90810, U.S.A

Tel: 888-4-ROBOTX (888-476-2689) | Fax: (310) 952-7502 | info@densorobotics.com

© 2011 DENSO Corporation

Information subject to change without notice

QR Code® is a registered trademark of DENSO WAVE INCORPORATED. All rights reserved.

DENSO
robotics

www.densorobotics.com